

STATE WHEN ORDERING

COW = mm
 CL = mm
 SBL = mm
 LAP = mm
 G = mm
 TDW = mm
 Door weight = kg

Surface treatment
 Silver anodized
 Special anodized
 RAL
 Special powder coating

	Alt.1	Alt.2	
Overlap (min. 20mm)	LAP	LAP x2 =
Finger protection (min. 25mm)	E	E x2 =
Finger protection (min. 25mm)	-	F x4 =
Jamb width (min. 30mm)	J	J x2 =
Leading edge width	-	P x4 =
Sum of above			Sum =

Alt.1 COW = K	K =	
Alt.2 COW + 4P + 4F = K	K =	(K + 4LAP) / 4 = TDW TDW =
Cover length CL	(CL - Sum) / 1,5 = = COW max.	
Door travel COW	(COW x1,5) + Sum = = CL min.	

Customer: _____

Door id: _____

Project No: _____

Ref: _____

Date: _____

Sign: _____

Sliding door operator
 Besam SL500 T-2
 Art. No. 1009282

ASSA ABLOY

2.0 1010710-EI

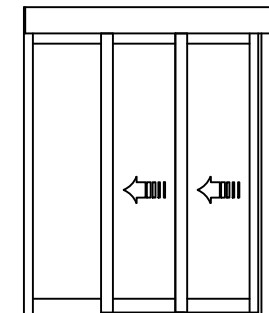
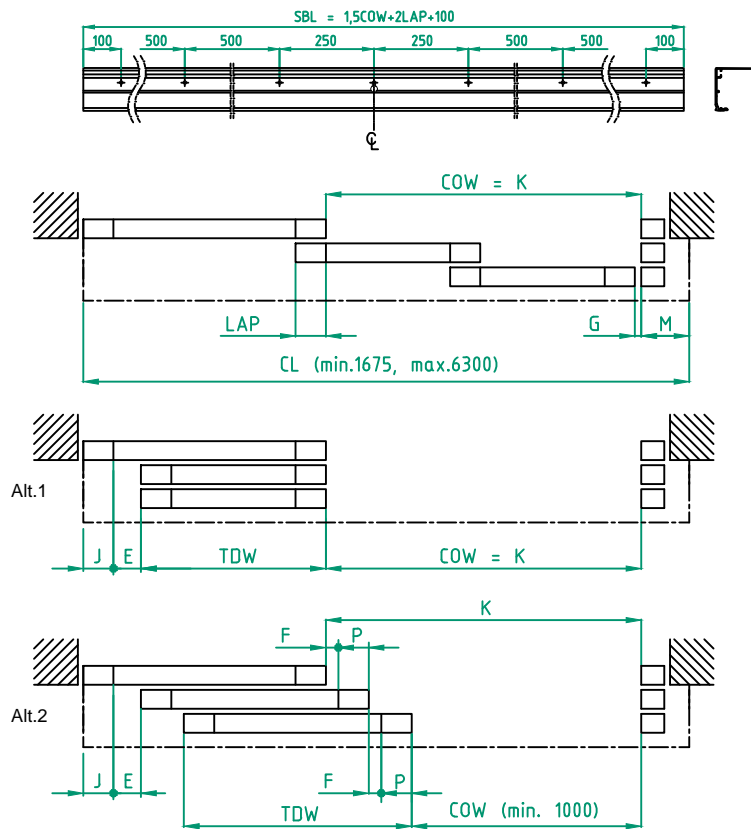
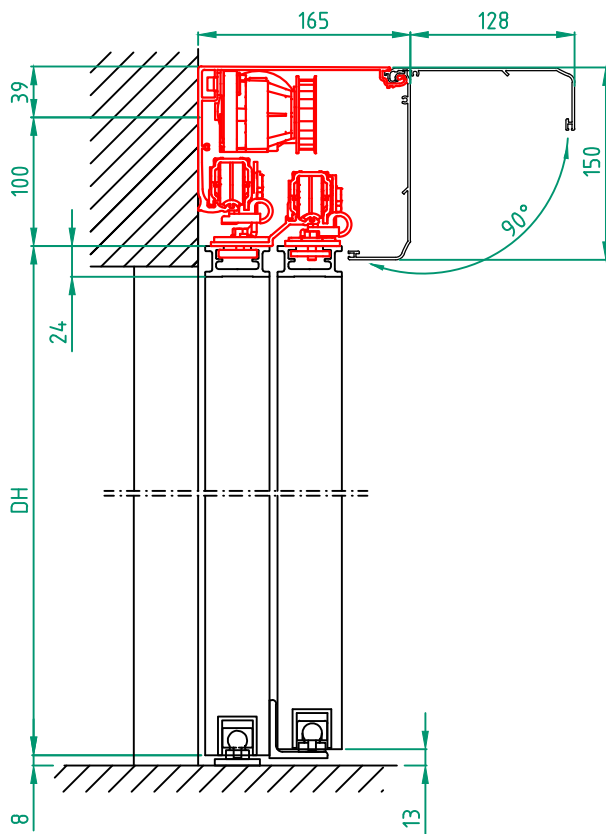

STATE WHEN ORDERING

- COW = mm
- CL = mm
- SBL = mm
- LAP = mm
- G = mm
- TDW = mm
- Door weight = kg

Surface treatment

- Silver anodized
- Special anodized
- RAL
- Special powder coating
-

	Alt.1	Alt.2	
Overlap (min. 20mm)	LAP	LAP
Finger protection (min. 25mm)	E	E
Finger protection (min. 25mm)	-	Fx2=
Jamb width (min. 30mm)	J	J
Cover overlap (min. 100mm)	M	M
Leading edge width	-	Px2=
Sum of above	Sum =		

Alt.1 COW = K	K=		
Alt.2 COW + 2P + 2F = K	K=	(K + 2LAP) / 2 = TDW	TDW =
Cover length CL	(CL - Sum) / 1,5 = = COW max.		
Door travel COW	(COW x1,5) + Sum = = CL min.		

Customer: _____

Door id: _____

Project No: _____

Ref: _____

Date: _____

Sign: _____

Sliding door operator
Besam SL500 T-L
Art. No. 1009282

ASSA ABLOY

2.0 1010710-EI

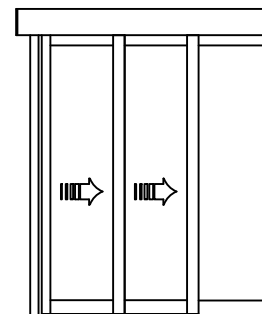
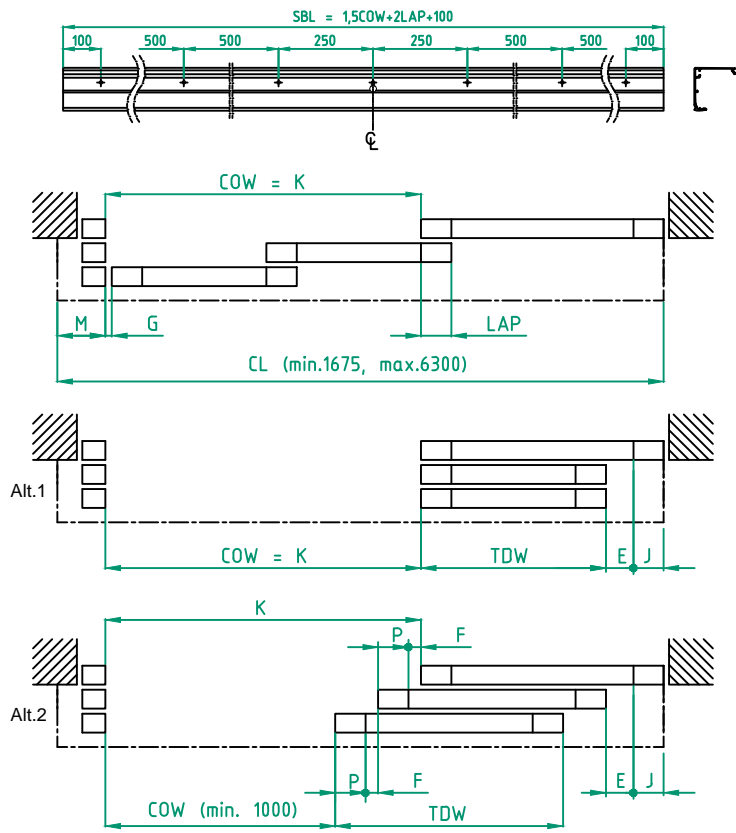
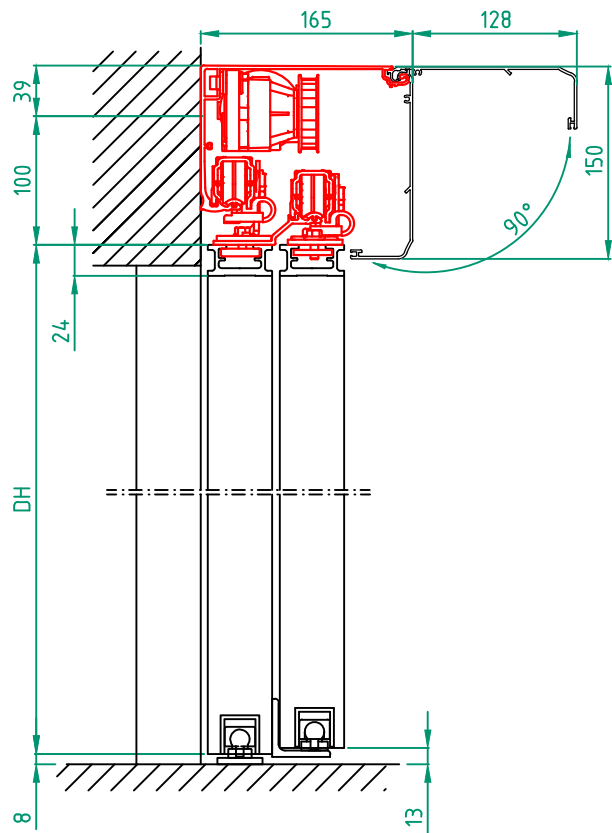

STATE WHEN ORDERING

COW = mm
 CL = mm
 SBL = mm
 LAP = mm
 G = mm
 TDW = mm
 Door weight = kg

Surface treatment

- Silver anodized
- Special anodized
- RAL
- Special powder coating
-

	Alt.1	Alt.2	
Overlap (min. 20mm)	LAP	LAP
Finger protection (min. 25mm)	E	E
Finger protection (min. 25mm)	-	Fx2=
Jamb width (min. 30mm)	J	J
Cover overlap (min. 100mm)	M	M
Leading edge width	-	Px2=
Sum of above	Sum =		

Alt.1 COW = K	K =	(K + 2LAP) / 2 = TDW	TDW =
Alt.2 COW + 2P + 2F = K	K =		
Cover length CL	(CL - Sum) / 1,5 = = COW max.		
Door travel COW	(COW x 1,5) + Sum = = CL min.		

Customer:

Ref:

Door id:

Date:

Project No:

Sign:

Sliding door operator

Besam SL500 T-R

Art. No. 1009282

ASSA ABLOY

2.0

1010710-EI